

45-48	6
30-44	1
DOOR OPNG.	T

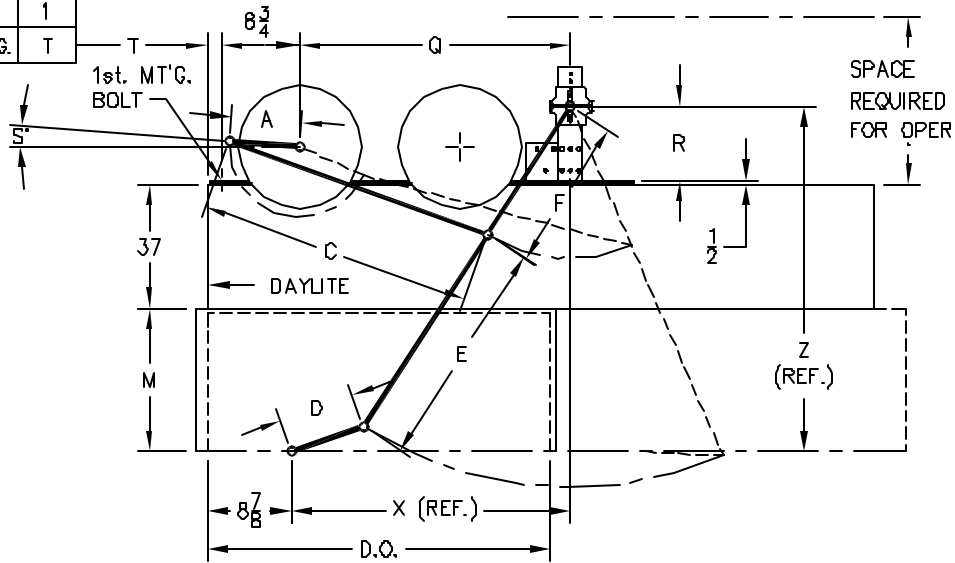

MOVFR	15
MOCT	
MOD	
MOM-MOH	19
MOMCT	
MOHCT	

48	7	34 <sup>7</sup> / <sub>8</sub>	12	52	21	23	39 <sup>5</sup> / <sub>8</sub>	71 <sup>1</sup> / <sub>2</sub>	33 <sup>1</sup> / <sub>4</sub>	11	5'
47	6 <sup>7</sup> / <sub>8</sub>	34 <sup>3</sup> / <sub>4</sub>	12	52	21	23	39 <sup>5</sup> / <sub>8</sub>	71 <sup>1</sup> / <sub>2</sub>	33 <sup>1</sup> / <sub>4</sub>	11	5'
46	6 <sup>3</sup> / <sub>4</sub>	34 <sup>5</sup> / <sub>8</sub>	12	52	21	23	39 <sup>5</sup> / <sub>8</sub>	71 <sup>1</sup> / <sub>2</sub>	33 <sup>1</sup> / <sub>4</sub>	11	5'
45	6 <sup>5</sup> / <sub>8</sub>	34 <sup>1</sup> / <sub>2</sub>	12	52	21	23	39 <sup>5</sup> / <sub>8</sub>	71 <sup>1</sup> / <sub>2</sub>	33 <sup>1</sup> / <sub>4</sub>	11	5'
44	7	36 <sup>5</sup> / <sub>8</sub>	10	44	22	19	34 <sup>5</sup> / <sub>8</sub>	64 <sup>1</sup> / <sub>2</sub>	33 <sup>1</sup> / <sub>4</sub>	8	12'
43	6 <sup>7</sup> / <sub>8</sub>	36 <sup>1</sup> / <sub>2</sub>	10	44	22	19	34 <sup>5</sup> / <sub>8</sub>	64 <sup>1</sup> / <sub>2</sub>	33 <sup>1</sup> / <sub>4</sub>	8	12'
42	6 <sup>3</sup> / <sub>4</sub>	36 <sup>3</sup> / <sub>8</sub>	10	44	22	19	34 <sup>5</sup> / <sub>8</sub>	64 <sup>1</sup> / <sub>2</sub>	33 <sup>1</sup> / <sub>4</sub>	8	12'
41	6 <sup>5</sup> / <sub>8</sub>	36 <sup>1</sup> / <sub>4</sub>	10	44	22	19	34 <sup>5</sup> / <sub>8</sub>	64 <sup>1</sup> / <sub>2</sub>	33 <sup>1</sup> / <sub>4</sub>	8	12'
40	6 <sup>1</sup> / <sub>2</sub>	36 <sup>1</sup> / <sub>8</sub>	10	44	22	19	34 <sup>5</sup> / <sub>8</sub>	64 <sup>1</sup> / <sub>2</sub>	33 <sup>1</sup> / <sub>4</sub>	8	12'
39	5 <sup>5</sup> / <sub>8</sub>	30 <sup>3</sup> / <sub>4</sub>	8	43	18	15	29 <sup>1</sup> / <sub>4</sub>	60	28 <sup>3</sup> / <sub>8</sub>	7 <sup>1</sup> / <sub>2</sub>	10'
38	5 <sup>1</sup> / <sub>2</sub>	30 <sup>5</sup> / <sub>8</sub>	8	43	18	15	29 <sup>1</sup> / <sub>4</sub>	60	28 <sup>3</sup> / <sub>8</sub>	7 <sup>1</sup> / <sub>2</sub>	10'
37	5 <sup>3</sup> / <sub>8</sub>	30 <sup>1</sup> / <sub>2</sub>	8	43	18	15	29 <sup>1</sup> / <sub>4</sub>	60	28 <sup>3</sup> / <sub>8</sub>	7 <sup>1</sup> / <sub>2</sub>	10'
36	5 <sup>1</sup> / <sub>4</sub>	30 <sup>3</sup> / <sub>8</sub>	8	43	18	15	29 <sup>1</sup> / <sub>4</sub>	60	28 <sup>3</sup> / <sub>8</sub>	7 <sup>1</sup> / <sub>2</sub>	10'
35	5 <sup>1</sup> / <sub>8</sub>	30 <sup>1</sup> / <sub>4</sub>	8	43	18	15	29 <sup>1</sup> / <sub>4</sub>	60	28 <sup>3</sup> / <sub>8</sub>	7 <sup>1</sup> / <sub>2</sub>	10'
34	5	26 <sup>3</sup> / <sub>4</sub>	6	44	19	15	25 <sup>1</sup> / <sub>4</sub>	61 <sup>7</sup> / <sub>8</sub>	24 <sup>3</sup> / <sub>8</sub>	9 <sup>3</sup> / <sub>8</sub>	10'
33	4 <sup>7</sup> / <sub>8</sub>	26 <sup>5</sup> / <sub>8</sub>	6	44	19	15	25 <sup>1</sup> / <sub>4</sub>	61 <sup>7</sup> / <sub>8</sub>	24 <sup>3</sup> / <sub>8</sub>	9 <sup>3</sup> / <sub>8</sub>	10'
32	4 <sup>3</sup> / <sub>4</sub>	26 <sup>1</sup> / <sub>2</sub>	6	44	19	15	25 <sup>1</sup> / <sub>4</sub>	61 <sup>7</sup> / <sub>8</sub>	24 <sup>3</sup> / <sub>8</sub>	9 <sup>3</sup> / <sub>8</sub>	10'
31	4 <sup>5</sup> / <sub>8</sub>	25 <sup>3</sup> / <sub>4</sub>	6	44	19	15	24 <sup>3</sup> / <sub>8</sub>	62 <sup>1</sup> / <sub>4</sub>	23 <sup>1</sup> / <sub>2</sub>	9 <sup>3</sup> / <sub>4</sub>	10'
30	4 <sup>1</sup> / <sub>2</sub>	25 <sup>5</sup> / <sub>8</sub>	6	44	19	15	24 <sup>3</sup> / <sub>8</sub>	62 <sup>1</sup> / <sub>4</sub>	23 <sup>1</sup> / <sub>2</sub>	9 <sup>3</sup> / <sub>4</sub>	10'
INCHES	A	C	D	E	F	M	X	Z	Q	R	S
DOOR OPENING	OPERATOR ARMS		DOOR ARMS			CLUTCH	PIVOT		OPERATOR		



SINGLE SPEED & TWO SPEED OPERATOR DATA TABLE  
30-48 D.O. FOR HIGH CABS 37" HEADER

FEB. 23 1987

S6898-37